



3.0V, $\pm 25\text{kV}$ ESD-Protected RS-232 Transceiver for PDAs and Cell Phones

MAX3386E

General Description

The MAX3386E 3V-powered EIA/TIA-232 and V.28/V.24 is a communications interface with low power requirements, high data-rate capabilities, and enhanced electrostatic discharge (ESD) protection. The MAX3386E has two receivers and three transmitters. All RS-232 inputs and outputs are protected to $\pm 25\text{kV}$ using the IEC 1000-4-2 Air-Gap Discharge method, $\pm 8\text{kV}$ using the IEC 1000-4-2 Contact Discharge method, and $\pm 15\text{kV}$ using the Human Body Model.

A proprietary low-dropout transmitter output stage enables true RS-232 performance from a +3.0V to +5.5V supply with a dual charge pump. The charge pump requires only four small $0.1\mu\text{F}$ capacitors for operation from a +3.3V supply. The MAX3386E is capable of running at data rates up to 250kbps while maintaining RS-232 compliant output levels.

The MAX3386E has a unique V_L pin that allows interoperation in mixed-logic voltage systems. Both input and output logic levels are pin programmable through the V_L pin. The MAX3386E is available in a space-saving TSSOP package.

Applications

Subnotebook/Palmtop Computers
PDAs and PDA Cradles
Cell Phone Data Cables
Battery-Powered Equipment
Hand-Held Equipment
Peripherals

Pin Configuration

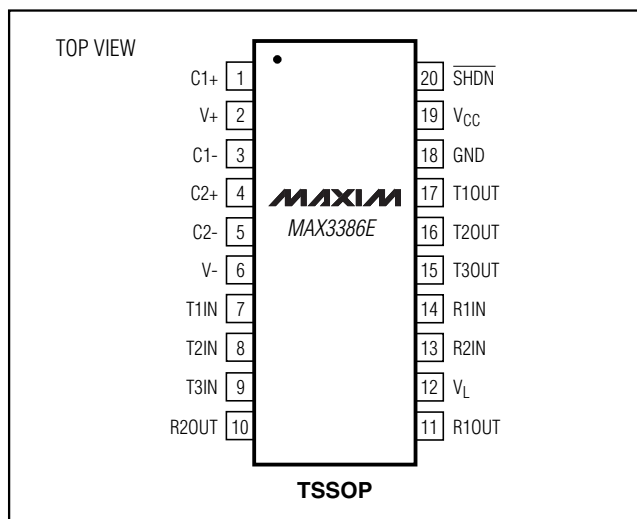

Features

- ◆ V_L Pin for Compatibility with Mixed-Voltage Systems
- ◆ Enhanced ESD Protection on Rx Inputs and Tx Outputs
 - ◆ $\pm 15\text{kV}$ —Human Body Model
 - ◆ $\pm 25\text{kV}$ —IEC 1000-4-2, Air-Gap Discharge
 - ◆ $\pm 8\text{kV}$ —IEC 1000-4-2, Contact Discharge
- ◆ Low $300\mu\text{A}$ Supply Current
- ◆ Guaranteed 250kbps Data Rate
- ◆ $1\mu\text{A}$ Low-Power Shutdown
- ◆ Meets EIA/TIA-232 Specifications Down to 3.0V

Ordering Information

PART	TEMP. RANGE	PIN-PACKAGE
MAX3386EUCP	0°C to $+70^\circ\text{C}$	20 TSSOP
MAX3386EEUP	-40°C to $+85^\circ\text{C}$	20 TSSOP

Typical Operating Circuit

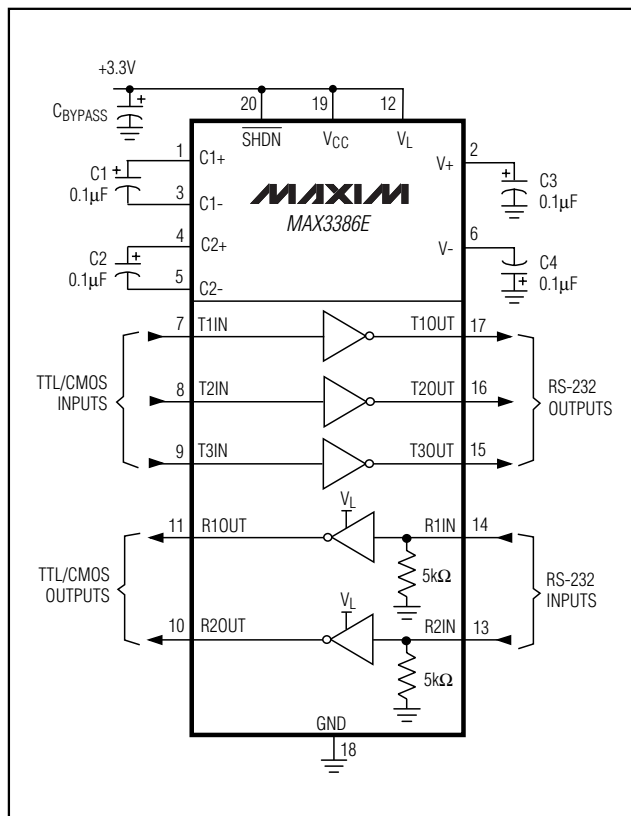

3.0V, ±25kV ESD-Protected RS-232 Transceiver for PDAs and Cell Phones

ABSOLUTE MAXIMUM RATINGS

V _{CC} to GND	-0.3V to +6V	Short-Circuit Duration T _{OUT} to GND	Continuous
V _L to GND	-0.3V to (V _{CC} + 0.3V)	Continuous Power Dissipation (T _A = +70°C)	
V ₊ to GND	-0.3V to +7V	20-Pin TSSOP (derate 7.0mW/°C above +70°C)	559mW
V ₋ to GND	+0.3V to -7V	Operating Temperature Ranges	
V ₊ + V ₋ (Note 1)	+13V	MAX3386ECUP	0°C to +70°C
Input Voltages		MAX3386EEUP	-40°C to +85°C
T _{IN} , SHDN to GND	-0.3V to +6V	Junction Temperature	+150°C
R _{IN} to GND	±25V	Storage Temperature Range	-65°C to +150°C
Output Voltages		Lead Temperature (soldering, 10s)	+300°C
T _{OUT} to GND	±13.2V		
R _{OUT}	-0.3V to (V _L + 0.3V)		

Note 1: V₊ and V₋ can have maximum magnitudes of 7V, but their absolute difference cannot exceed 13V.

Stresses beyond those listed under "Absolute Maximum Ratings" may cause permanent damage to the device. These are stress ratings only, and functional operation of the device at these or any other conditions beyond those indicated in the operational sections of the specifications is not implied. Exposure to absolute maximum rating conditions for extended periods may affect device reliability.

DC ELECTRICAL CHARACTERISTICS

(V_{CC} = V_L = +3.0V to +5.5V; C1–C4 = 0.1μF, tested at +3.3V ±10%; C1 = 0.047μF, C2–C4 = 0.33μF, tested at +5.0V ±10%; T_A = T_{MIN} to T_{MAX}; unless otherwise noted. Typical values are at V_{CC} = V_L = +3.3V, T_A = +25°C.)

PARAMETER	SYMBOL	CONDITIONS	MIN	TYP	MAX	UNITS
DC CHARACTERISTICS (V _{CC} = +3.3V or +5V, T _A = +25°C)						
Shutdown Supply Current		$\overline{\text{SHDN}}$ = GND, all inputs at V _{CC} or GND		1	10	μA
Supply Current		$\overline{\text{SHDN}}$ = V _{CC} , no load		0.3	1	mA
LOGIC INPUTS						
Input Logic Threshold Low		T _{IN} , $\overline{\text{SHDN}}$	V _L = 3.3V or 5.0V		0.8	V
			V _L = 2.5V		0.6	
Input Logic Threshold High		T _{IN} , $\overline{\text{SHDN}}$	V _L = 5.0V	2.4		V
			V _L = 3.3V	2.0		
			V _L = 2.5V	1.4		
			V _L = 1.8V	0.9		
Transmitter Input Hysteresis				0.5		V
Input Leakage Current		T _{IN} , $\overline{\text{SHDN}}$		±0.01	±1	μA
RECEIVER OUTPUTS						
Output Leakage Currents		R _{OUT} , receivers disabled		±0.05	±10	μA
Output Voltage Low		I _{OUT} = 1.6mA			0.4	V
Output Voltage High		I _{OUT} = -1mA	V _L - 0.6	V _L - 0.1		V
RECEIVER INPUTS						
Input Voltage Range			-25		+25	V
Input Threshold Low		T _A = +25°C	V _L = 5.0V	0.8	1.2	V
			V _L = 3.3V	0.6	1.5	
Input Threshold High		T _A = +25°C	V _L = 5.0V	1.8	2.4	V
			V _L = 3.3V	1.5	2.4	
Input Hysteresis				0.5		V
Input Resistance		T _A = +25°C	3	5	7	kΩ

3.0V, ±25kV ESD-Protected RS-232 Transceiver for PDAs and Cell Phones

MAX3386E

DC ELECTRICAL CHARACTERISTICS (continued)

($V_{CC} = V_L = +3.0V$ to $+5.5V$; $C1-C4 = 0.1\mu F$, tested at $+3.3V \pm 10\%$; $C1 = 0.047\mu F$, $C2-C4 = 0.33\mu F$, tested at $+5.0V \pm 10\%$; $T_A = T_{MIN}$ to T_{MAX} ; unless otherwise noted. Typical values are at $V_{CC} = V_L = +3.3V$, $T_A = +25^\circ C$.)

PARAMETER	SYMBOL	CONDITIONS	MIN	TYP	MAX	UNITS
TRANSMITTER OUTPUTS						
Output Voltage Swing		All transmitter outputs loaded with $3k\Omega$ to ground	±5	±5.4		V
Output Resistance		$V_{CC} = V_+ = V_- = 0$, transmitter output = $\pm 2V$	300	10M		Ω
Output Short-Circuit Current		$V_{T_OUT} = 0$			±60	mA
Output Leakage Current		$V_{T_OUT} = \pm 12V$, transmitters disabled; $V_{CC} = 0$ or $3.0V$ to $5.5V$			±25	μA
ESD PROTECTION						
R _{IN} , T _{OUT} ESD Protection		Human Body Model		±15		kV
		IEC 1000-4-2 Air-Gap Discharge method		±25		
		IEC 1000-4-2 Contact Discharge method		±8		

TIMING CHARACTERISTICS

($V_{CC} = V_L = +3V$ to $+5.5V$; $C1-C4 = 0.1\mu F$, tested at $+3.3V \pm 10\%$; $C1 = 0.047\mu F$, $C2-C4 = 0.33\mu F$, tested at $+5.0V \pm 10\%$; $T_A = T_{MIN}$ to T_{MAX} ; unless otherwise noted. Typical values are at $V_{CC} = V_L = +3.3V$, $T_A = +25^\circ C$.)

PARAMETER	SYMBOL	CONDITIONS	MIN	TYP	MAX	UNITS
Maximum Data Rate		$R_L = 3k\Omega$, $C_L = 1000pF$, one transmitter switching	250			kbps
Receiver Propagation Delay	t _{PHL}	Receiver input to receiver output, $C_L = 150pF$		0.15		μs
	t _{PLH}			0.15		
Receiver Output Enable Time				200		ns
Receiver Output Disable Time				200		ns
Time to Exit Shutdown		$ V_{T_OUT} > 3.7V$		100		μs
Transmitter Skew	t _{PHL} - t _{PLH}	(Note 2)		100		ns
Receiver Skew	t _{PHL} - t _{PLH}			50		ns
Transition-Region Slew Rate		$V_{CC} = 3.3V$, $T_A = +25^\circ C$, $R_L = 3k\Omega$ to $7k\Omega$, measured from $+3V$ to $-3V$ or $-3V$ to $+3V$	$C_L = 150pF$ to $1000pF$	6	30	V/ μs
			$C_L = 150pF$ to $2500pF$	4	30	

Note 2: Transmitter skew is measured at the transmitter zero crosspoint.

3.0V, ±25kV ESD-Protected RS-232 Transceiver for PDAs and Cell Phones

Typical Operating Characteristics

(VCC = VL = +3.3V, TA = +25°C, unless otherwise noted.)

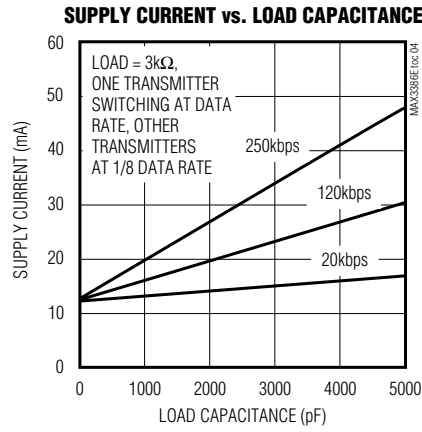
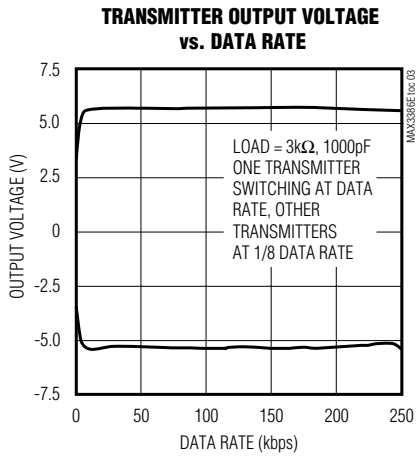
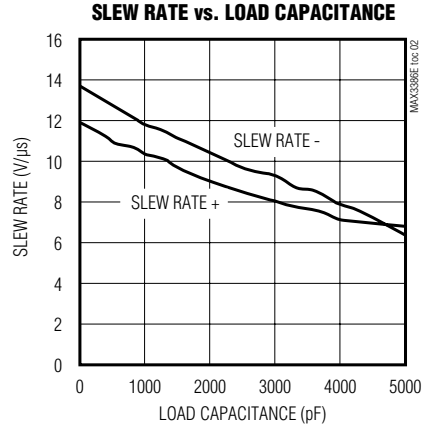
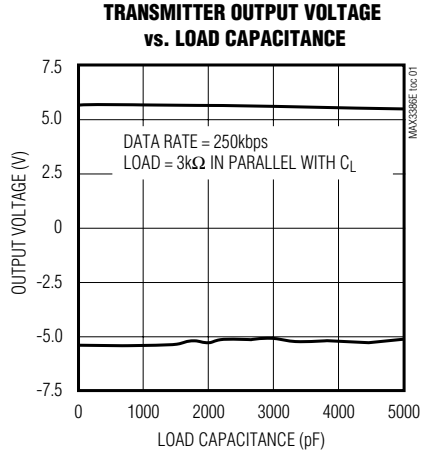

3.0V, ±25kV ESD-Protected RS-232 Transceiver for PDAs and Cell Phones

Pin Description

MAX3386E

PIN	NAME	FUNCTION
1	C1+	Positive Terminal of the Voltage-Doubler Charge-Pump Capacitor
2	V+	+5.5V Supply Generated by the Charge Pump
3	C1-	Negative Terminal of the Voltage-Doubler Charge-Pump Capacitor
4	C2+	Positive Terminal of the Inverting Charge-Pump Capacitor
5	C2-	Negative Terminal of the Inverting Charge-Pump Capacitor
6	V-	-5.5V Generated by the Charge Pump
7	T1IN	TTL/CMOS Transmitter Inputs
8	T2IN	
9	T3IN	
10	R2OUT	TTL/CMOS Receiver Outputs. Swing between 0 and V _L .
11	R1OUT	
12	V _L	Logic-Level Supply. All CMOS inputs and outputs are referenced to this supply.
13	R2IN	RS-232 Receiver Inputs
14	R1IN	
15	T3OUT	RS-232 Transmitter Outputs
16	T2OUT	
17	T1OUT	
18	GND	Ground
19	V _{CC}	+3.0V to +5.5V Supply Voltage
20	$\overline{\text{SHDN}}$	Shutdown Input. 0 = shutdown, 1 = normal operation.

3.0V, ±25kV ESD-Protected RS-232 Transceiver for PDAs and Cell Phones

Detailed Description

Dual Charge-Pump Voltage Converter

The MAX3386E's internal power supply consists of a regulated dual charge pump that provides output voltages of +5.5V (doubling charge pump) and -5.5V (inverting charge pump), regardless of the input voltage (V_{CC}) over a +3.0V to +5.5V range. The charge pumps operate in a discontinuous mode: if the output voltages are less than 5.5V, the charge pumps are enabled; if the output voltages exceed 5.5V, the charge pumps are disabled. Each charge pump requires a flying capacitor (C1, C2) and a reservoir capacitor (C3, C4) to generate the V_+ and V_- supplies.

RS-232 Transmitters

The transmitters are inverting level translators that convert CMOS-logic levels to 5.0V EIA/TIA-232 levels.

The MAX3386E's transmitters guarantee a 250kbps data rate with worst-case loads of $3k\Omega$ in parallel with $1000pF$, providing compatibility with PC-to-PC communication software (such as LapLink™). Transmitters can be paralleled to drive multiple receivers or mice. Figure 1 shows a complete system connection.

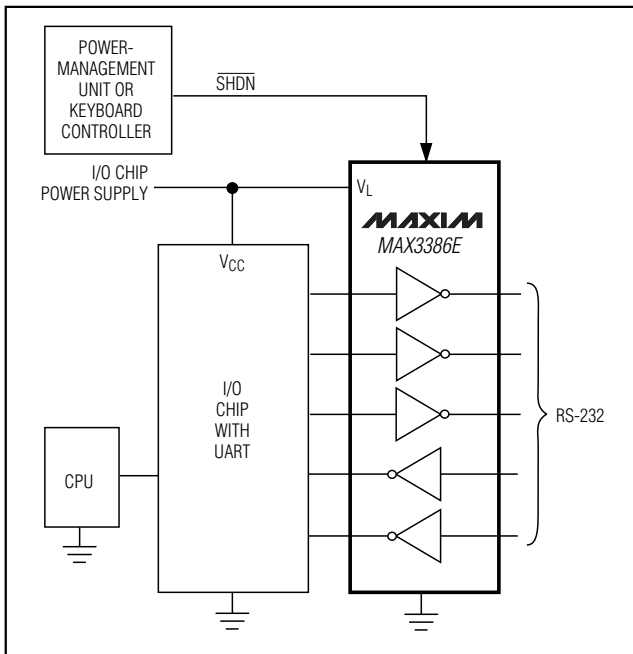

Figure 1. Interface Under Control of PMU

These RS-232 output stages are turned off (high impedance) when the device is in shutdown mode. When the power is off, the MAX3386E permits the outputs to be driven up to $\pm 12V$.

The transmitter inputs do not have pull-up resistors. Connect unused inputs to GND or V_L .

RS-232 Receivers

The receivers convert RS-232 signals to CMOS-logic output levels. The MAX3386E's receivers have inverting three-state outputs, which depend on the shutdown state of the device.

Shutdown Mode

Supply current falls to less than $1\mu A$ when the MAX3386E is placed in shutdown mode (SHDN logic low). When shut down, the device's charge pumps are turned off, V_+ decays to V_{CC} , V_- is pulled to ground, and the transmitter outputs are disabled (high impedance). The time required to exit shutdown is typically $100\mu s$, as shown in Figure 2. Connect SHDN to V_{CC} if the shutdown mode is not used. In shutdown mode, the receiver outputs are high impedance (Table 1).

Table 1. Shutdown Logic Truth Table

SHDN	TRANSMITTER OUTPUTS	RECEIVER OUTPUTS	CHARGE PUMP
L	High-Z	High-Z	Inactive
H	Active	Active	Active

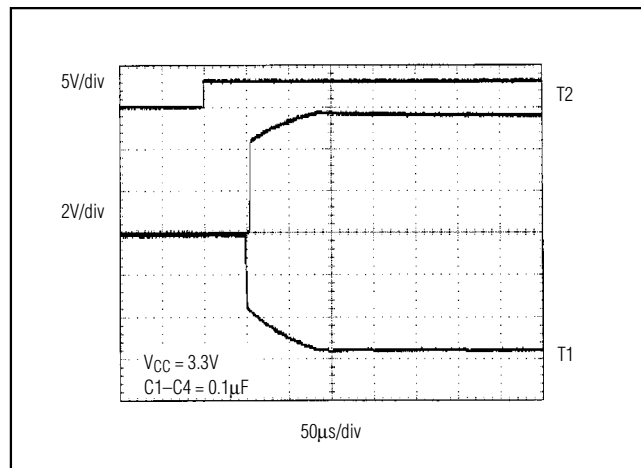

Figure 2. Transmitter Outputs when Exiting Shutdown

LapLink is a trademark of Traveling Software.

3.0V, ±25kV ESD-Protected RS-232 Transceiver for PDAs and Cell Phones

MAX3386E

V_L Logic Supply Input

Unlike other RS-232 interface devices where the receiver outputs swing between 0 and V_{CC}, the MAX3386E features a separate logic supply input (V_L) that sets V_{OH} for the receiver outputs and sets thresholds for the transmitted and shutdown inputs. This feature allows a great deal of flexibility in interfacing to many different types of systems with different logic levels. Connect this input to the host logic supply (1.8V ≤ V_L ≤ V_{CC}). Also see the *Typical PDA/Cell-Phone Application* section.

±25kV ESD Protection

As with all Maxim devices, ESD-protection structures are incorporated on all pins to protect against electrostatic discharges (ESDs) encountered during handling and assembly. The MAX3386E's driver outputs and receiver inputs have extra protection against static electricity. Maxim has developed state-of-the-art structures to protect these pins against an ESD of ±25kV without damage. The ESD structures withstand high ESD in all states: normal operation, shutdown, and powered down. After an ESD event, Maxim's "E" version devices keep working without latchup, whereas competing RS-232 products can latch and must be powered down to remove latchup. ESD protection can be tested in various ways. The transmitter outputs and receiver inputs of this product family are characterized for protection to the following limits:

- 1) ±15kV using the Human Body Model
- 2) ±8kV using the Contact Discharge method specified in IEC 1000-4-2
- 3) ±25kV using IEC 1000-4-2's Air-Gap Discharge method

ESD Test Conditions

ESD performance depends on a variety of conditions. Contact Maxim for a reliability report that documents test setup, methodology, and results.

Human Body Model

Figure 3a shows the Human Body Model, and Figure 3b shows the current waveform it generates when discharged into a low impedance. This model consists of a 100pF capacitor charged to the ESD voltage of interest, which is then discharged into the test device through a 1.5kΩ resistor.

IEC 1000-4-2

The IEC 1000-4-2 standard covers ESD testing and performance of finished equipment; it does not specifically refer to ICs. The MAX3386E helps you design equipment that meets Level 4 (the highest level) of IEC

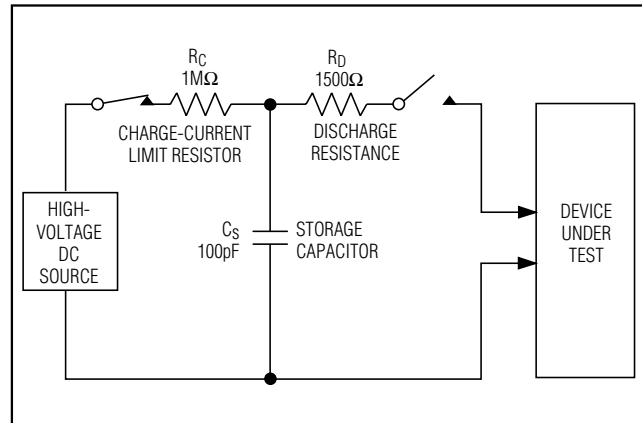

Figure 3a. Human Body ESD Test Model

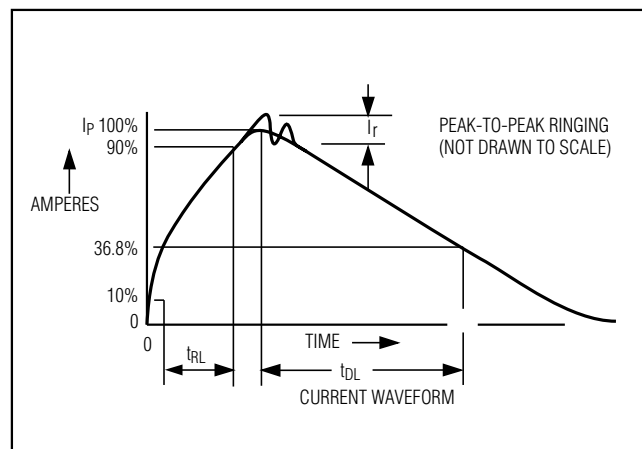

Figure 3b. Human Body Current Waveform

1000-4-2, without the need for additional ESD-protection components.

The major difference between tests done using the Human Body Model and IEC 1000-4-2 is higher peak current in IEC 1000-4-2, because series resistance is lower in the IEC 1000-4-2 model. Hence, the ESD withstand voltage measured to IEC 1000-4-2 is generally lower than that measured using the Human Body Model. Figure 4a shows the IEC 1000-4-2 model, and Figure 4b shows the current waveform for the ±8kV IEC 1000-4-2 Level 4 ESD Contact-Discharge test.

The air-gap test involves approaching the device with a charged probe. The contact-discharge method connects the probe to the device before the probe is energized.

3.0V, ±25kV ESD-Protected RS-232 Transceiver for PDAs and Cell Phones

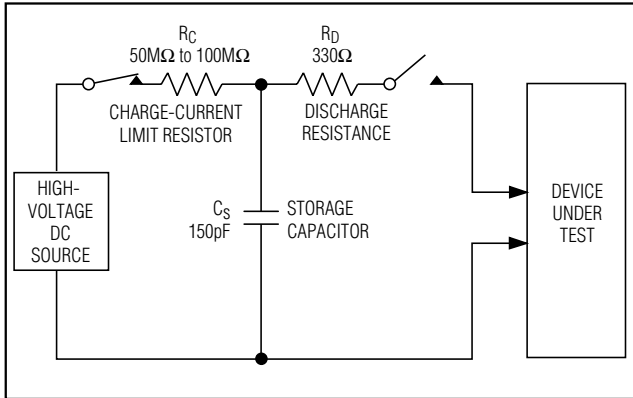

Figure 4a. IEC 1000-4-2 ESD Test Model

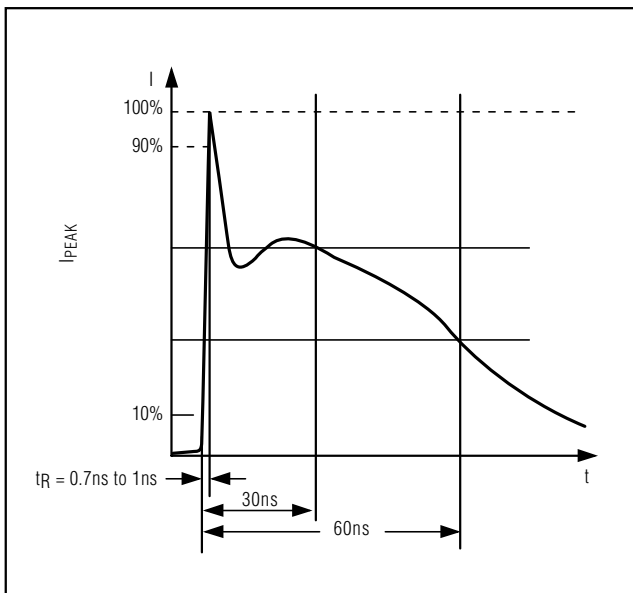

Figure 4b. IEC 1000-4-2 ESD Generator Current Waveform

Table 2. Minimum Required Capacitor Values

V _{CC} (V)	C1 (μF)	C2, C3, C4 (μF)
3.0 to 3.6	0.1	0.1
4.5 to 5.5	0.047	0.33
3.0 to 5.5	0.22	1

Machine Model

The Machine Model for ESD tests all pins using a 200pF storage capacitor and zero discharge resistance. Its objective is to emulate the stress caused by contact that occurs with handling and assembly during manufacturing. All pins require this protection during manufacturing, not just RS-232 inputs and outputs. Therefore, after PC board assembly, the Machine Model is less relevant to I/O ports.

Applications Information

Capacitor Selection

The capacitor type used for C1–C4 is not critical for proper operation; polarized or nonpolarized capacitors can be used. The charge pump requires 0.1μF capacitors for 3.3V operation. For other supply voltages, see Table 2 for required capacitor values. Do not use values smaller than those listed in Table 2. Increasing the capacitor values (e.g., by a factor of 2) reduces ripple on the transmitter outputs and slightly reduces power consumption. C2, C3, and C4 can be increased without changing C1's value. However, do not increase C1 without also increasing the values of C2, C3, and C4 to maintain the proper ratios (C1 to the other capacitors).

When using the minimum required capacitor values, make sure the capacitor value does not degrade excessively with temperature. If in doubt, use capacitors with a larger nominal value. The capacitor's equivalent series resistance (ESR), which usually rises at low temperatures, influences the amount of ripple on V₊ and V₋.

Power-Supply Decoupling

In most circumstances, a 0.1μF bypass capacitor is adequate. In applications that are sensitive to power-supply noise, decouple V_{CC} to ground with a capacitor of the same value as charge-pump capacitor C1. Connect bypass capacitors as close to the IC as possible.

Operation Down to 2.7V

Transmitter outputs will meet EIA/TIA-562 levels of ±3.7V with supply voltages as low as +2.7V.

Transmitter Outputs when Exiting Shutdown

Figure 2 shows two transmitter outputs when exiting shutdown mode. As they become active, the two transmitter outputs are shown going to opposite RS-232 levels (one transmitter input is high; the other is low). Each transmitter is loaded with 3kΩ in parallel with 2500pF. The transmitter outputs display no ringing or undesirable transients as they come out of shutdown. Note that the transmitters are enabled only when the magnitude of V₋ exceeds approximately 3V.

3.0V, ±25kV ESD-Protected RS-232 Transceiver for PDAs and Cell Phones

MAX3386E

High Data Rates

The MAX3386E maintains the RS-232 $\pm 5.0V$ minimum transmitter output voltage even at high data rates. Figure 5 shows a transmitter loopback test circuit. Figure 6 shows a loopback test result at 120kbps, and Figure 7 shows the same test at 250kbps. For Figure 6, all transmitters were driven simultaneously at 120kbps into RS-232 loads in parallel with 1000pF. For Figure 7, a single transmitter was driven at 250kbps, and all transmitters were loaded with an RS-232 receiver in parallel with 1000pF.

Interconnection with 3V and 5V Logic

The MAX3386E can directly interface with various 5V logic families, including ACT and HCT CMOS. The logic voltage power-supply pin V_L sets the output voltage level of the receivers and the input thresholds of the transmitters.

Typical PDA/Cell-Phone Application

The MAX3386E is designed with PDA applications in mind. Two transmitters and two receivers handle standard full-duplex communication protocol, while an extra transmitter allows a ring indicator (RI) signal to alert the UART on the PC. Without the ring indicator transmitter, solutions for these applications would require software-intensive polling of the cradle inputs.

The RI signal is generated when a PDA, cellular phone, or other "cradled" device is plugged into its cradle. This generates a logic-low signal to RI transmitter input, creating +6V at the ring indicate pin. The PC's UART RI input is the only pin that can generate an interrupt from signals arriving through the RS-232 port. The interrupt routine for this UART will then service the RS-232 full-duplex communication between the PDA and the PC.

As cell phone design becomes more like that of PDAs, cell phones will require similar docking ability and communication protocol. Cell phones operate on a single lithium-ion (Li+) battery and work with a power-supply voltage of +2.7V to +4V. The baseband logic coming from the phone connector can be as low as 1.8V at the transceivers. To prevent forward biasing of a device internal to the cell phone, the MAX3386E comes with a logic power-supply pin (V_L) that limits the logic levels presented to the phone. The receiver outputs will sink to zero for low outputs, but will not exceed V_L for logic highs. The input logic levels for the transmitters are also altered, scaled by the magnitude of the V_L input. The device will work with V_L as low as 1.8V before the charge-pump noise will begin to cause the transmitter outputs to oscillate. This is useful with cell phones and other power-efficient devices with core logic voltage levels that go as low as 1.8V.

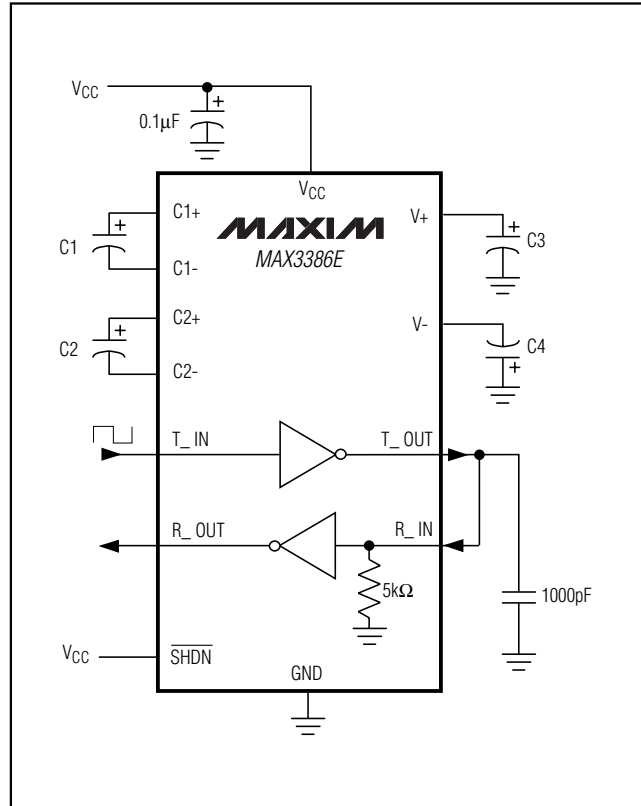

Figure 5. Loopback Test Circuit

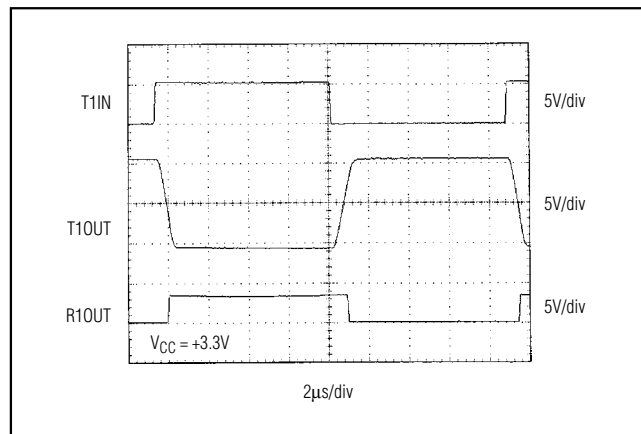

Figure 6. Loopback Test Results at 120kbps

3.0V, ±25kV ESD-Protected RS-232 Transceiver for PDAs and Cell Phones

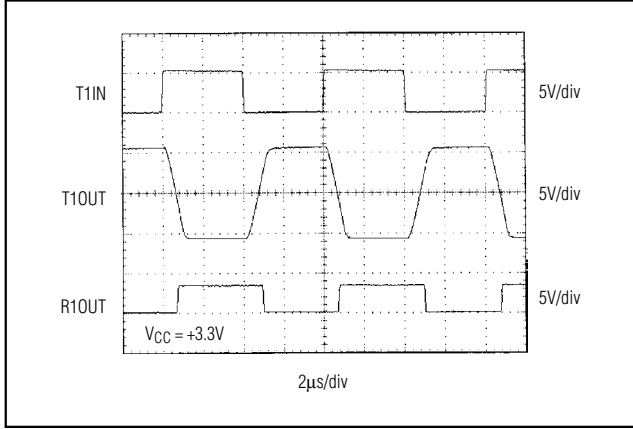

Figure 7. Loopback Test Results at 250kbps

Chip Information

TRANSISTOR COUNT: 1267

3.0V, ±25kV ESD-Protected RS-232 Transceiver for PDAs and Cell Phones

Package Information

MAX3386E

SYMBOL	COMMON DIMENSIONS			
	MILLIMETERS		INCHES	
	MIN.	MAX.	MIN.	MAX.
A	—	1.10	—	.043
A ₁	0.05	0.15	.002	.006
A ₂	0.85	0.95	.033	.037
b	0.19	0.30	.007	.012
b1	0.19	0.25	.007	.010
c	0.090	0.20	.0035	.008
c1	0.090	0.135	.0035	.0053
D	SEE VARIATIONS		SEE VARIATIONS	
E	4.30	4.50	.169	.177
ε	.065 BSC		.026 BSC	
H	6.25	6.50	.246	.256
L	0.50	0.70	.020	.028
N	SEE VARIATIONS		SEE VARIATIONS	
Y	2.85	3.15	.112	.124
α	0°	8°	0°	8°

JEDEC	N	VARIATIONS				
		MILLIMETERS		INCHES		
		MIN.	MAX.	MIN.	MAX.	
AB	14	D	4.90	5.10	.193	.201
AC	16	D	4.90	5.10	.193	.201
AC-EP	16	D	4.90	5.10	.193	.201
		X	2.85	3.15	.112	.124
AD	20	D	6.40	6.60	.252	.260
AD-EP	20	D	6.40	6.60	.252	.260
		X	4.00	4.34	.157	.171
AE	24	D	7.70	7.90	.303	.311
AF	28	D	9.60	9.80	.378	.386
AF-EP		D	9.60	9.80	.378	.386
		X	5.35	5.65	.211	.222

NOTES:
 1. DIMENSIONS D AND E DO NOT INCLUDE FLASH.
 2. MOLD FLASH OR PROTRUSIONS NOT TO EXCEED .15 mm PER SIDE.
 3. CONTROLLING DIMENSION: MILLIMETER.
 4. MEETS JEDEC OUTLINE MO-153 VARIATIONS AB, AC, AD, AE, AF.
 5. DIMENSIONS X AND Y APPLY TO EXPOSED PAD (EP) VERSIONS ONLY.
 6. EXPOSED PAD FLUSH WITH BOTTOM OF PACKAGE WITHIN .002".

PROPRIETARY INFORMATION
 TITLE: PACKAGE OUTLINE, TSSOP, 4.40mm BODY, 0.65mm PITCH
 APPROVAL: _____ DOCUMENT CONTROL NO: 21-0066 REV: C 1/1

TSSOP:EPS

Maxim cannot assume responsibility for use of any circuitry other than circuitry entirely embodied in a Maxim product. No circuit patent licenses are implied. Maxim reserves the right to change the circuitry and specifications without notice at any time.